

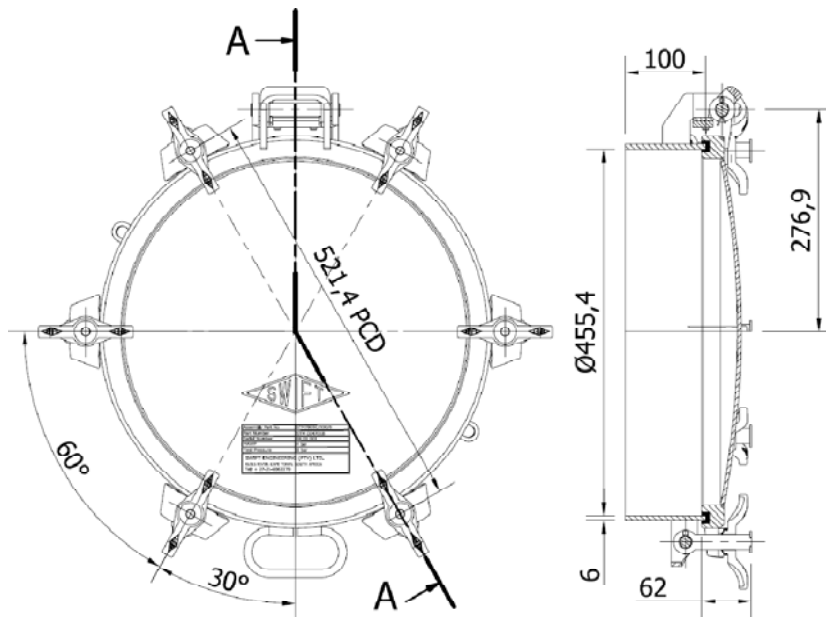

460MM MANHOLE ASSEMBLY



DESCRIPTION

Manlid: 6-point swing bolt bracketed domed manlid
Neck and Compensating Ring Assembly: Consists of a low profile neck ring welded to a compensating ring, with 6 swing bolts

SPECIFICATIONS

MAWP: 4 bar (58 psi)
Test Pressure: 6 bar (87 psi)
Design Temperature: -40 °C (-40°F) to 180°C (356 °F)
Weight: 36 kg

OPTIONS

- Straight neck or Compensated version
- 100mm, 150mm or 200mm neckring height
- Tank radii from 850mm to 1220mm
- Insulated / Double skin lid
- Protruding/Non-protruding neckring
- Option of brass/stainless steel wing/hex nuts

MARKINGS

The following is pin-stamped on the assembly:

- Swift logo
- Assembly & part number
- MAWP
- Other markings specified by the customer

SUB-ASSEMBLIES

1. Lid assembly
2. Low profile neckring assembly
3. Swing bolt & hinge pin assemblies
4. Seal (supplied separately)

MATERIAL

The contact parts are manufactured in Stainless Steel 316 and 316L. Non-contact parts in Stainless Steel 304. The 4.4mm domed dish in SANS 50028-7 W1.4402 CR.

DESIGN CODES AND APPROVALS

ASME VIII Div. 1
RID/ADR
IMDG
BUREAU VERITAS

FINISH

Lids are electro-polished and neckrings are blasted and pickled.

